

NOTE: ALL DIMNS. ARE IN INCHES

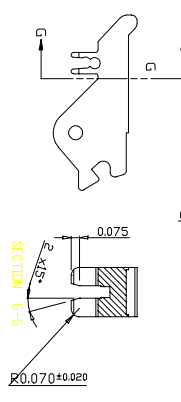
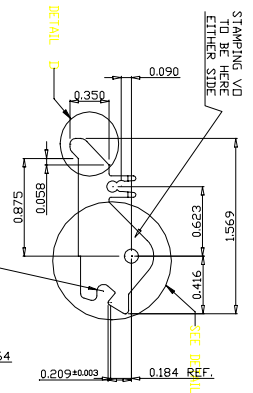
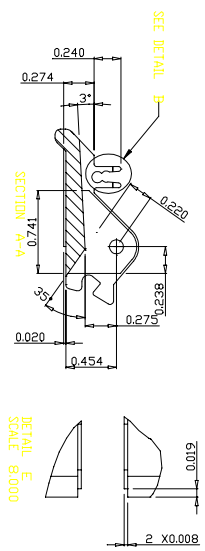
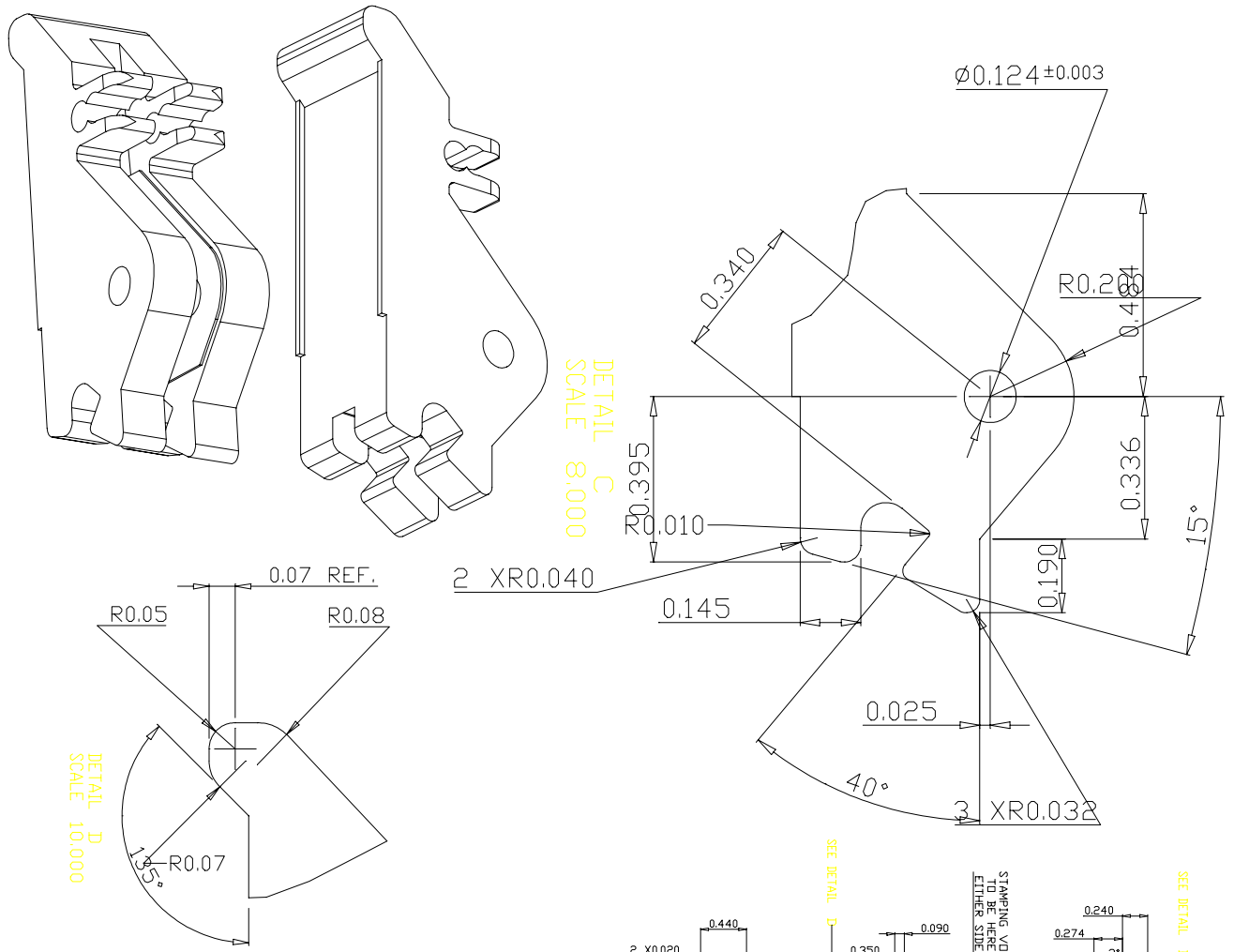

MATERIAL REFERENCE CHART	
MATERIAL CODE	MATERIAL DESCRIPTION
J	Polycarbonate, Lexan 940, Meets UL94-V0, Stock Color: Black.

S.NO	PART NO	CARD THICK.	MOUNTING PIN	MATERIAL CODE
1	LR1039-B	0.093	Ø1/8 x 3/8	J

PART NAME: EJECTOR		DATE		SIGN	
DRN. BY	CHK. BY				
PART NO : LR1039-B					
SHEET 1 OF 1					
DO NOT SCALE THE DRAWING		TOLERANCE			
		.XX = ± 0.020			
		.XX = ± 0.010			
		.XXX = ± 0.005			

**MICRO DIMENSIONAL INC.**  
 548 NORTH TROOPER ROAD, NORRISTOWN, PA 19403